

Hisey Bells hanging systems

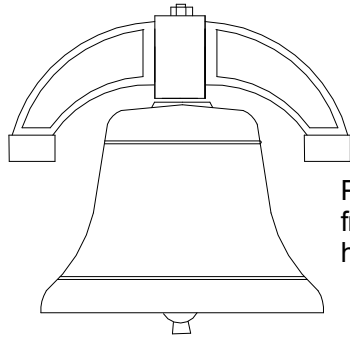

Plain metal free-swinging hanger

These three hanging styles use pillow block bearings (not shown) to attach to stands, windows, and various other structures allowing a free-swinging motion. All include ringer arms. (not shown)

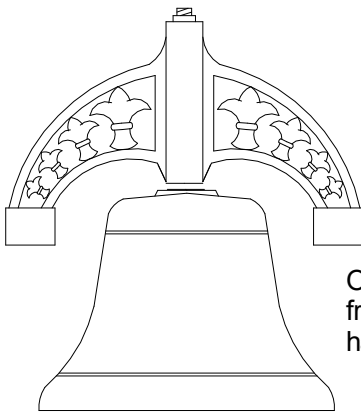

Ornate metal free-swinging hanger

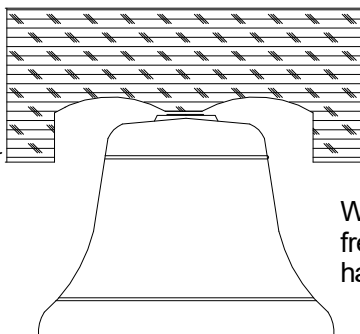

Wooden free-swinging hanger

Automated or manual electric ringer

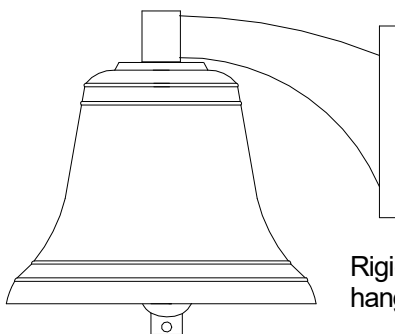
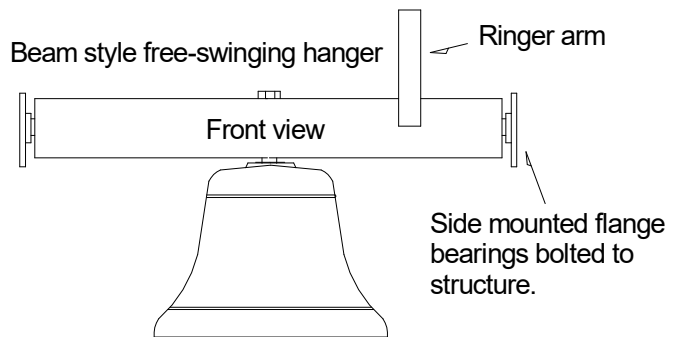
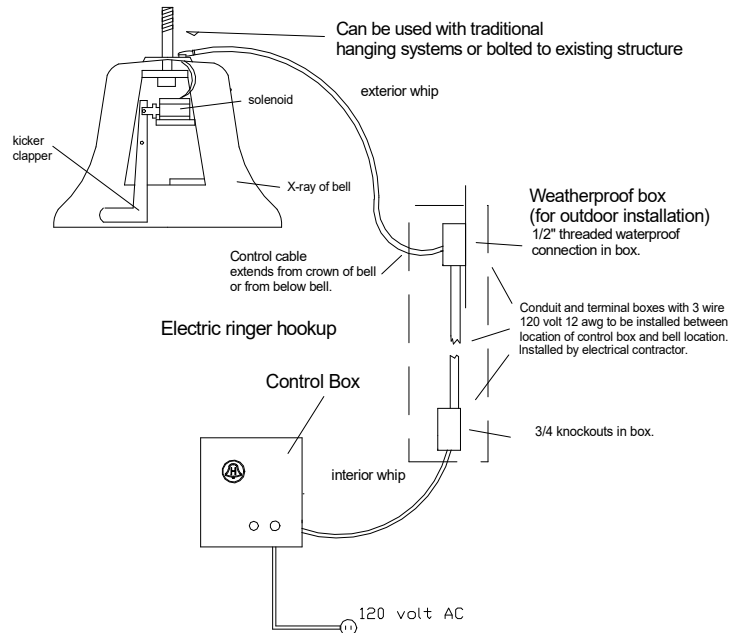

Rigid single arm hanger

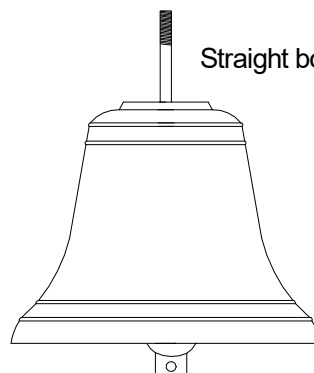

Straight bolt-on